









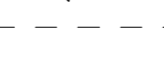
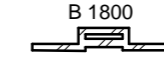
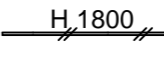

LEGEND

-  VANDAL RESISTANT LIGHT TO ELECTRICAL ENG. SPEC.
-  BOLLARD LIGHT TO ELECTRICAL ENGINEER DRAWING AND SPEC.
-  NEW GATE TO SPEC.
-  NEW BRICK PAVING TO SPEC.
-  EXISTING SPOT LEVELS
-  EXISTING FENCE, PATH OR KERB TO BE REMOVED
-  B 1800 BRICK WALL AT HEIGHT NOMINATED
-  H 1800 NEW FIBRO FENCE HEIGHT NOTED
-  C 1800 NEW COLORBOND HEIGHT NOTED
-  EXISTING RANCH FENCING
-  TREE TO REMAIN
-  TREE TO BE REMOVED
-  NEW KERBING
-  STUMP TO BE REMOVED

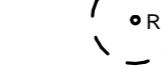
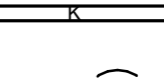
SITE PLAN 1:100

DATUM NAIL IN PATH
RL 9.977 ASSUMED

PROPOSED UPGRADE
OF 5 EXISTING UNITS
#30 CHARLES STREET
MIDLAND

DRAWING TITLE		SITE PLAN	
REV.	DESCRIPTION	DATE	

SCALE: 1:100 DATE: 09-11-01 CHECKED: GD
DRAWN: KD PROJECT NO: 01.007 A16 PREPARED: MDA

PLOTTED: 11/02/2005 4:56 PM

MORLEY DAVIS architects
architecture · interior · planning · project management

107 Cambridge Street, West Leederville WA 6007
Tel: (08) 9388 7777 Fax: (08) 9388 7755
Email: mda@morleydavis.com.au ABRN 61 4 05 811 799

THIS DRAWING IS COPYRIGHT PROTECTED. IT SHALL NOT BE USED WITHOUT THE LICENCE FROM MORLEY DAVIS ARCHITECTS PTY LTD.

MDa